

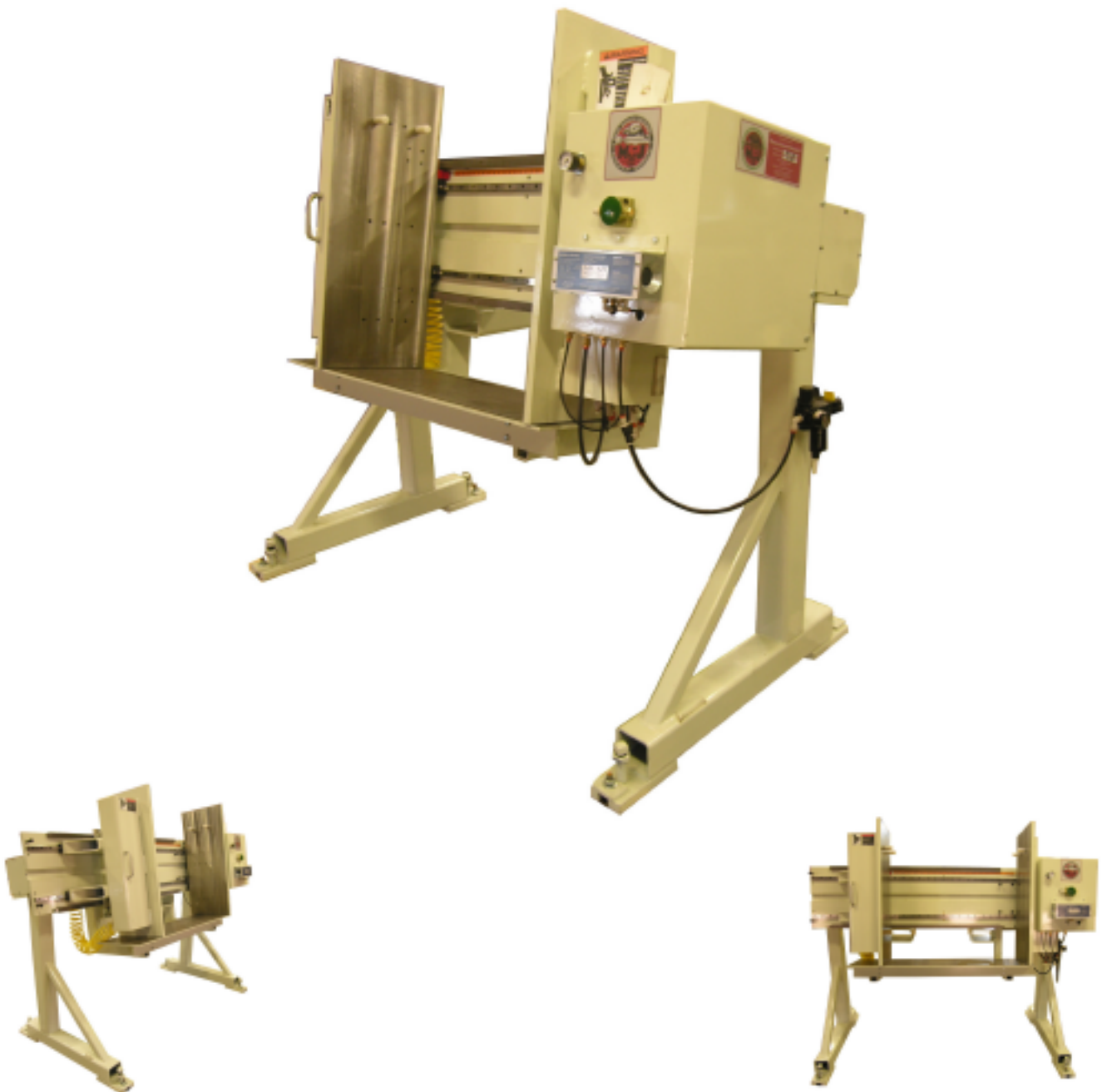

# MEREEN-JOHNSON

---

## Model 99-D Box Press



---

**For Fast and Accurate Assembly of Box Goods**

# Model 99-D Drawer Box Press

The Mereen-Johnson Model 99-D drawer box press solves the problem faced by both large and small shops that need to assemble box components into a finished product quickly, accurately, and efficiently.

The adjustable horizontal carriage glides easily on THK linear rails and automatically locks in position when clamp is actuated. Only compressed air is required for operation; no electrical power is required. Clamping controls are conveniently located, easy to use, and require both hands to actuate for safety.

The result is a compact unit that offers quick setup for the assembly of a wide variety of boxes that utilize dovetailed and doweled joints. The Mereen-Johnson Model 99-D will speed up your operation, improve product accuracy and increase your shops efficiencies.

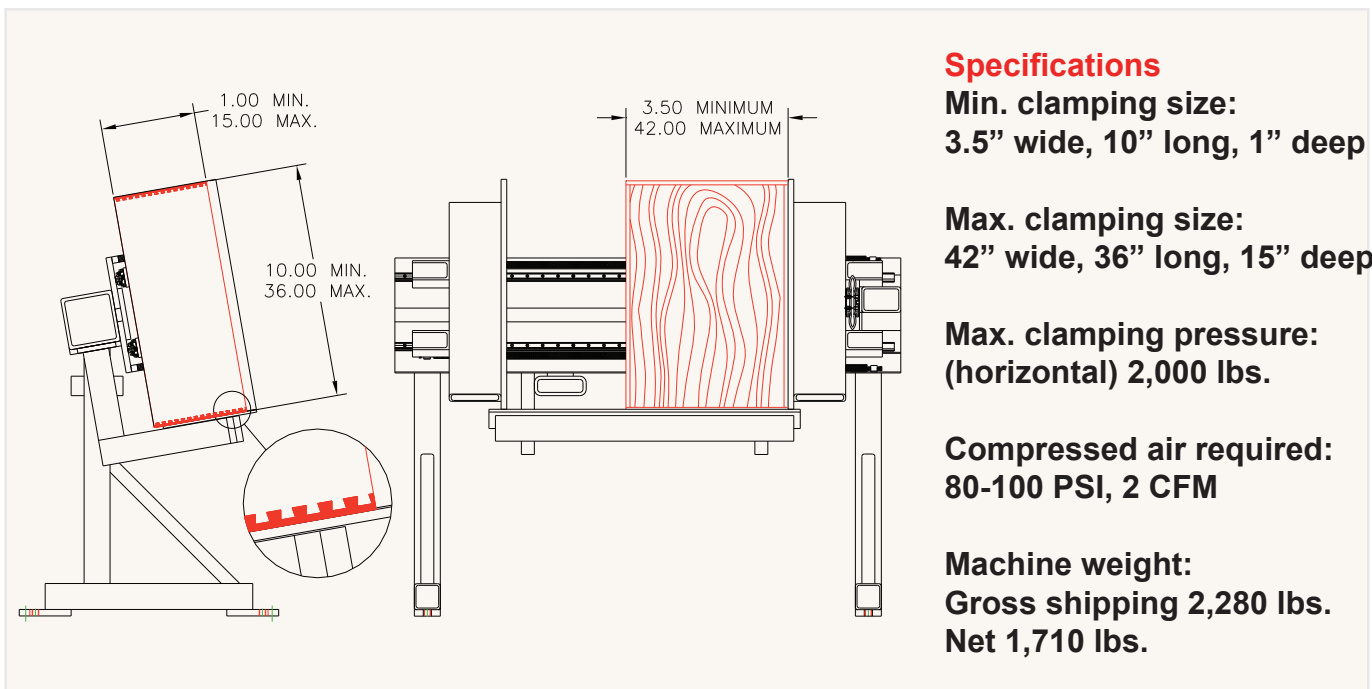

## Features and Benefits

- Adjustable clamp rides on linear bearings for free floating horizontal positioning and features automatic lock actuation. Simply slide the clamp to position and actuate the clamp.
- Heavy duty steel plate and tube frame with 10 degree fixed tilt for optimum ergonomics.
- Two hand clamp actuation for operator safety. Single hand release.
- Full width lower support shelf, open top access, and multi-position stock locating pins facilitate "On machine" box assembly.
- No tools required for operation or set-up.

**Setting the Standard**

